

Circuits 3

Name & Set

- 1 What resistances can be made by using three resistors each of 5Ω ? In each case draw a diagram of the arrangement and calculate its equivalent resistance. You must use all the resistors each time.

[3]

- 2 How many resistors of resistance 7Ω each are required to make a resistor of 1Ω ? How must they be connected?

[2]

- 3 You are provided with resistors of 1Ω , 2Ω & 3Ω . What is the minimum and maximum resistance that can be made using all of them? Show working and draw diagrams of the arrangements.

- 4 How must a resistor of 30Ω be connected between the points A & B in the circuit shown in diagram 1 below to make the resistance between them (a) 15Ω and (b) 27.5Ω ?

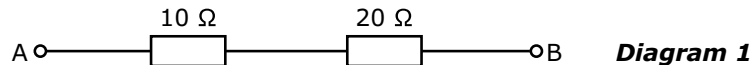

(a) _____

[3]

(b) _____

[3]

AS Electricity

- 5 What resistor must be used in the circuit shown in diagram 2 below, and how should it be connected so as to make the resistance between A and B (a) twice what it is and (b) $\frac{2}{3}$ of what it is?

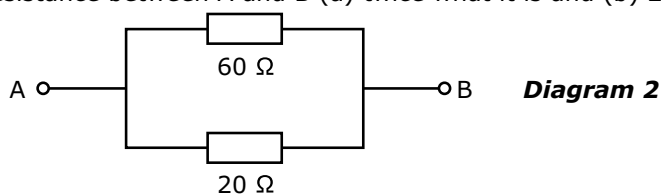

(a) _____

_____ [3]

(b) _____

_____ [3]

- 6 Two resistors are connected in parallel across a battery with negligible internal resistance, as shown in diagram 3.

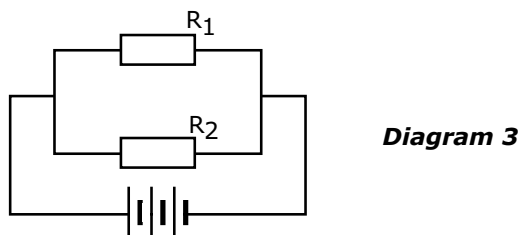

The current through resistor R_1 is 2.00 A, and the current through resistor R_2 is 3.00 A. What will be the current in the circuit if the two resistors are now connected in series instead of in parallel? Show all working.

_____ [3]

- 7 It is possible to run a small lamp rated at 1.5V, 0.25A from a 9V battery by putting a suitable resistance into the circuit?

(a) Draw a circuit diagram below to show how the resistor and bulb must be connected.

(b) Calculate the value of the resistor.

_____ [3]

AS Electricity

- 8 In the circuit shown in diagram 4 a high resistance voltmeter reads 4 V when connected between A & B. The same voltmeter reads 2 V when connected between B & C. C is a zero potential.

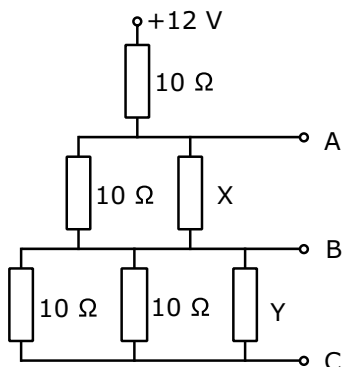

Diagram 4

- (a) What will the voltmeter read when it is connected across the top resistor?

_____ [1]

- (b) Calculate the current through this resistor.

_____ [2]

- (c) Calculate values for resistors marked X and Y.

_____ [3]

- 9 A string of Christmas lights consists of 40 small bulbs. It is plugged directly into the 240V mains.

- (a) How must the lamps be connected and why?

_____ [2]

- (b) What is the p.d. across each lamp?

_____ [2]

- (c) If each lamp is designed to carry a current of 0.25A, calculate the resistance of each bulb.

_____ [2]

- (d) There is a type of Christmas lamp that will not cause the whole string to go out if it fails. The secret is that a resistor is placed in parallel with the filament so if the filament fails, a current will still flow through the rest of the lamps. What should the resistance of this resistor be with respect to that of the filament? Will it be much larger, much less or exactly the same? Explain your choice of answer.

_____ [3]

10 Resistors of 5Ω , 10Ω and 15Ω are connected as shown in diagram 5. The p.d. between A & B is 2.2V

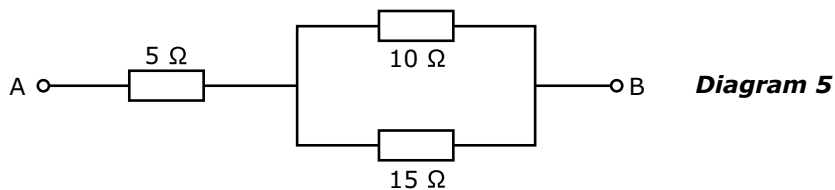

Calculate:

(a) the total circuit resistance

[3]

(b) the circuit current

[3]

(c) the p.d. across each of the resistors.

[3]

Extension problem

1 A multimeter set to the appropriate range is used to measure the resistance of the circuit below.

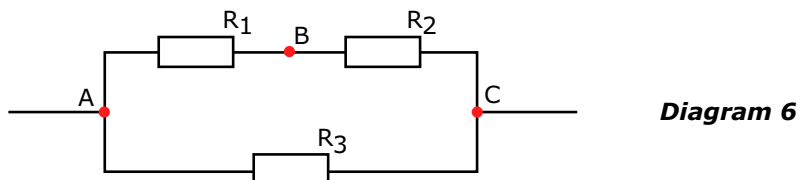

It is found that the resistance between A & B is 1.5Ω , between B & C it is 1.33Ω and between A & C it is 0.83Ω

To make it easier to calculate values for the resistors a wire is used to short circuit AC while measuring the resistance between AB. The multimeter then reads 0.67Ω .

Use these measurements to calculate values for R_1 , R_2 and R_3 .

[5]