

GCSE Electrical circuits

Name & Set

- 1 (a) Figure 1 shows a torch, which requires two cells to function properly. L is the bulb and S is the switch. Using the usual symbols draw a circuit diagram for the torch to show how it works.

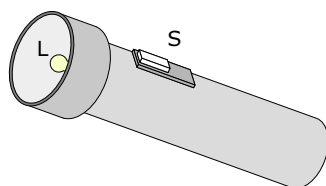
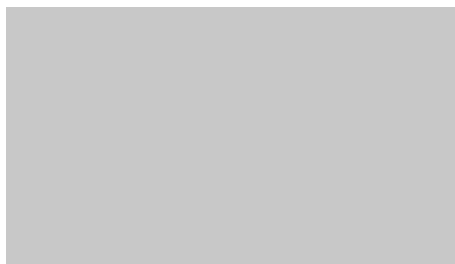

Fig 1



[3]

- (b) An investigation is to be carried out into the effect that increasing the potential difference, V , has on the current, I , passing through a torch bulb.

- (i) Figure 2 below shows a partially completed circuit diagram. Complete the diagram showing where a voltmeter and an ammeter should be connected in order to measure the potential difference across it and the current passing through it. [3]

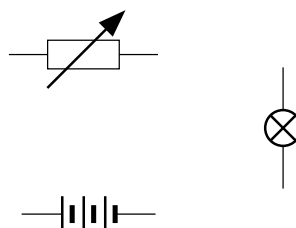

Fig 2

- (ii) What is the purpose of the variable resistor in this circuit?

_____ [2]

- (c) In an experiment with this apparatus the following set of readings were obtained.

Potential difference / V	0	1.00	2.00	3.00	4.00	5.00
Current / A	0	0.10	0.16	0.20	0.23	0.24

- (i) Use these values to plot a graph of current (x-axis) against p.d. (y-axis) [6]

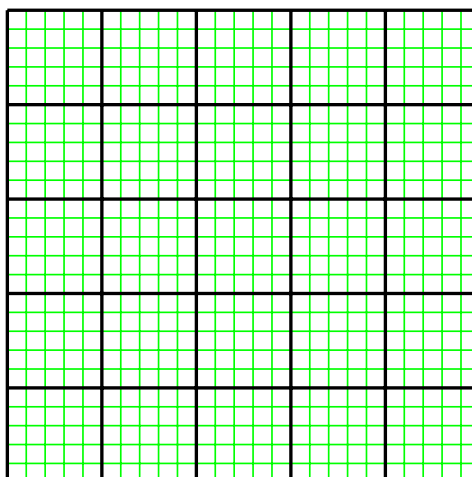

(d) (i) Write down in words in the space below the equation that links resistance, potential difference and current.

(ii) Complete the following table using the results for the variation of current with p.d. above. [3]

Potential difference / V	0	1.00	2.00	3.00	4.00	5.00
Current / A	0	0.10	0.16	0.20	0.23	0.24
Resistance / Ohms						

(iii) Use these values to plot a graph of p.d. (x-axis) against resistance (y-axis) [6]

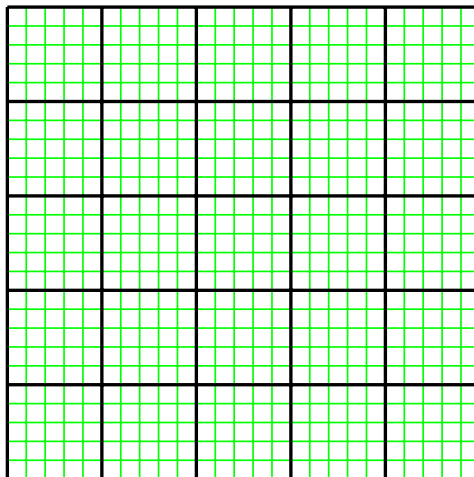

(iv) What occurs to the resistance of the filament as the p.d. across it is increased? How does your graph support your answer?

[3]

(v) Does the filament of the bulb obey Ohm's Law? Justify your answer.

[2]

2 This question is about an automatic washing machine. The diagram below shows an expanded view of the washing machine.

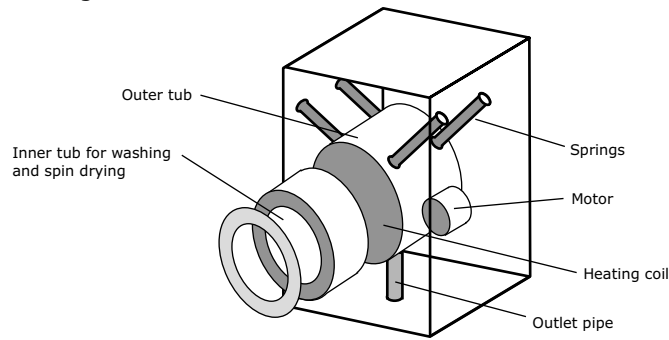

On the wash cycle, the heater and the motor are on at the same time. Each requires a potential difference of 240 V to work correctly.

(a) In the space below, draw a labelled circuit diagram to show how they should be connected to the supply. Use the symbols given below.

Include **one** fuse for the whole appliance and a switch that can be used to control the current to the heater. [5]

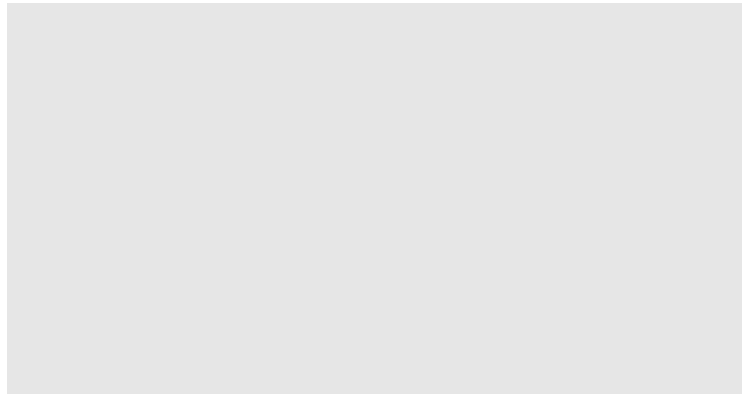

Component	Symbol
Heater	
Electric motor	
a.c. supply	
Fuse	
Switch	

(b) Write down in words the equation that links electrical power, voltage and current

_____ [1]

(c) The maximum power rating of the washing machine is 3.0 kW at 240 V. Calculate the maximum current to the washing machine.

 _____ [2]

(d) Why should an electrical appliance such as a washing machine be fused? Where would you expect to find a fuse?

[2]

(e) Explain how a fuse works.

[2]

(f) Fuses are available as 3A, 5A and 13 A. Which of these would you choose to use with the washing machine?

[1]

(g) The average power rating of the washing machine during a wash cycle is 1.5 kW, and the time taken for one wash cycle is 30 minutes. If the cost per unit of electricity is 8 p calculate the weekly cost of using the washing machine if 8 washes are done per week

[3]

1 The diagram shows part of a ring main in a house. Three appliances, with their operating voltages and powers, are also represented.

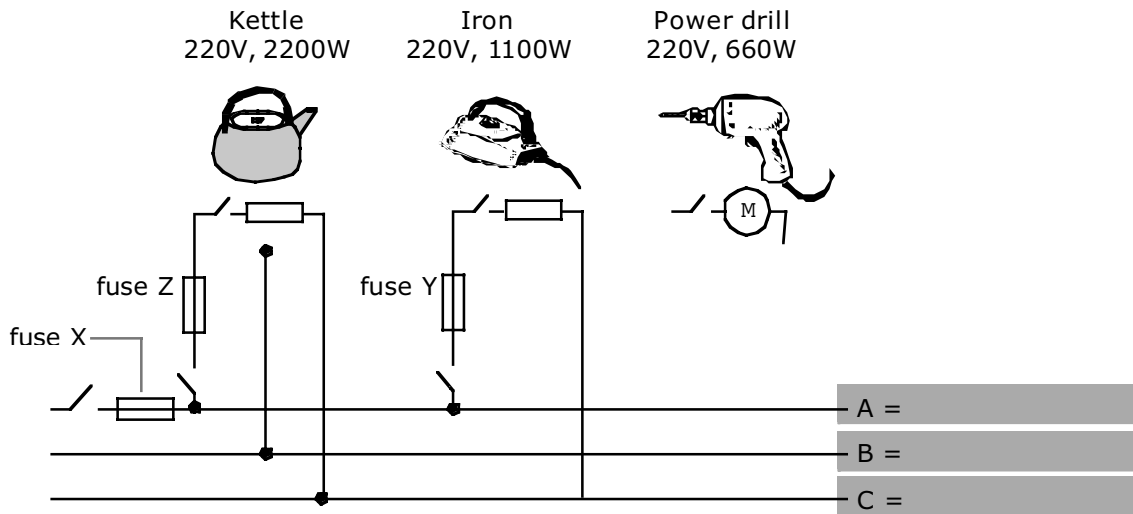

(a) On the diagram,
 (i) label the live wire with a letter L, the neutral wire with a letter N and the earth wire with a letter E. [3]

(ii) complete the circuit from the main to the power drill. The power drill is double insulated (i.e. it has a plastic casing). [2]

(b) (i) Write down in words the equation that links electrical power, voltage and current.

_____ [1]

(ii) Calculate the current to the kettle.

_____ [2]

(ii) While the kettle is boiling water, the iron is switched on. Calculate the current that flows through fuse Y.

_____ [1]

(c) George turns off the main switch and fits a 13 A fuse for fuse X. He switches on the main switch and the kettle. The kettle works. He then switches on the iron as well.

(i) What would you expect to happen to fuse X?

_____ [1]

(ii) George replaces the 13 A fuse with a 30 A fuse. Some time later a fault develops so that when George switches the kettle on fuse Z melts. Describe a fault that could cause fuse Z to melt.

_____ [1]

(iii) If fuse Z melts what, if anything, happens to fuse Y?

_____ [1]